



HENDRIKX CONCRETE PTY LTD

417 PRINCES HIGHWAY, OFFICER, VIC 3809

ABN: 12 067 076 751 ACN: 067 076 751

TEL: (03) 5943 2321 FAX: (03) 5943 1221

EMAIL: sales@hendrikkxconcrete.com.au

WEBSITE: www.hendrikkxconcrete.com.au

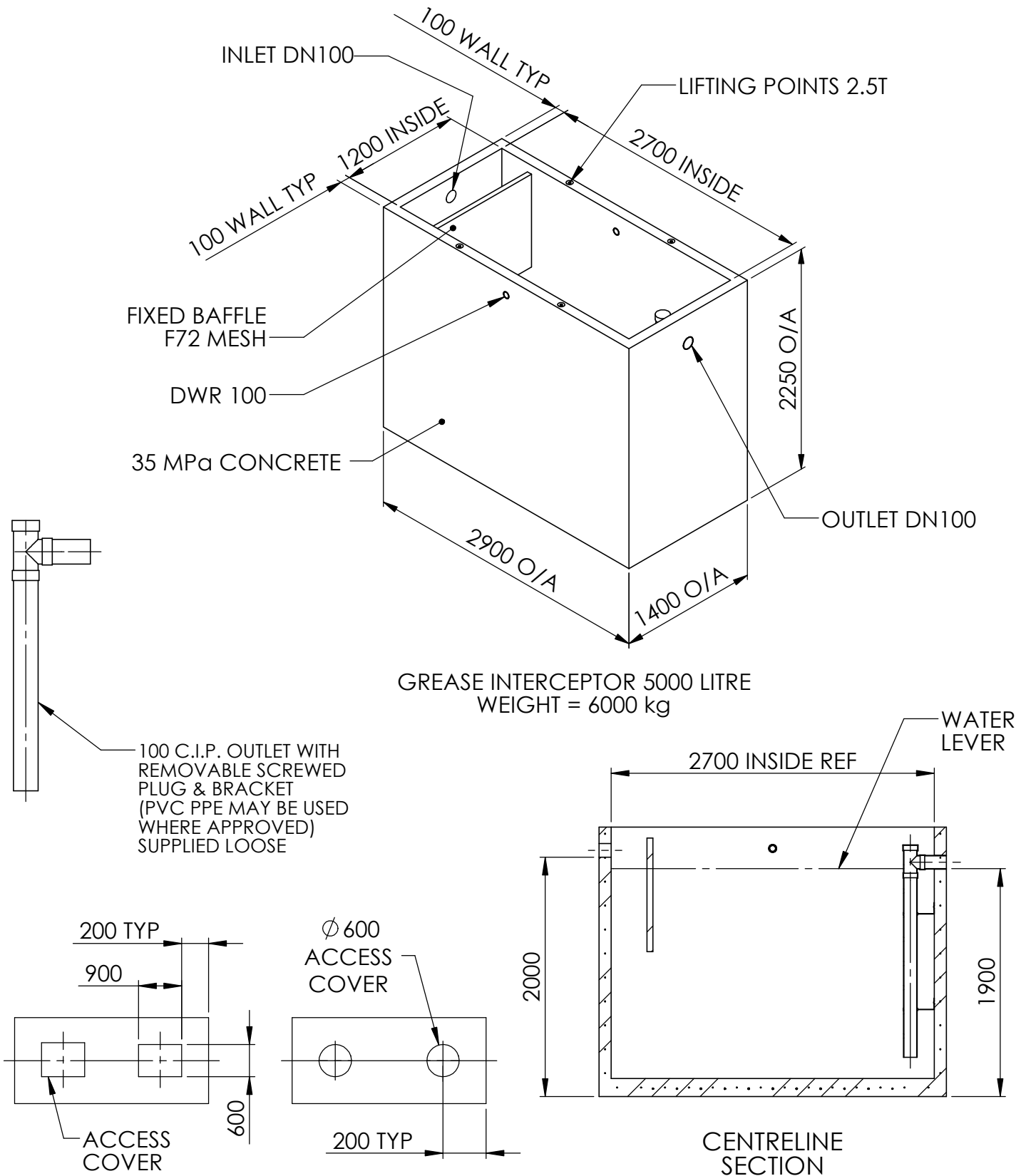

NOTES:

1. DO NOT SCALE.
2. SLIGHT TAPER ON CONCRETE UNITS.
3. MEASUREMENT IN MILLIMETRES.

LIDS:

AVAILABLE IN CONCRETE, 2900 x 1400 mm
LIGHT = 150 THK, HEAVY = 250 THK

Drawing Number: 13-HDC-075-I	Title: GREASE INTERCEPTOR 5000L - INFORMATION	Drawn: EV	Date: 14.07.14	Rev: 2
--	---	---------------------	--------------------------	------------------