

HENDRIKX CONCRETE PTY LTD

ABN: 12 067 076 751

417 PRINCES HIGHWAY

TEL: 03 5943 2321

Email: sales@hendrikxconcrete.com.au

ACN: 067 076 751

OFFICER VIC 3809

FAX: 03 5943 1221

Web Site: www.hendrikxconcrete.com.au

WEIGHT 200 KGS	DRAWING NO: HEN 1
----------------	-------------------

SILT PIT

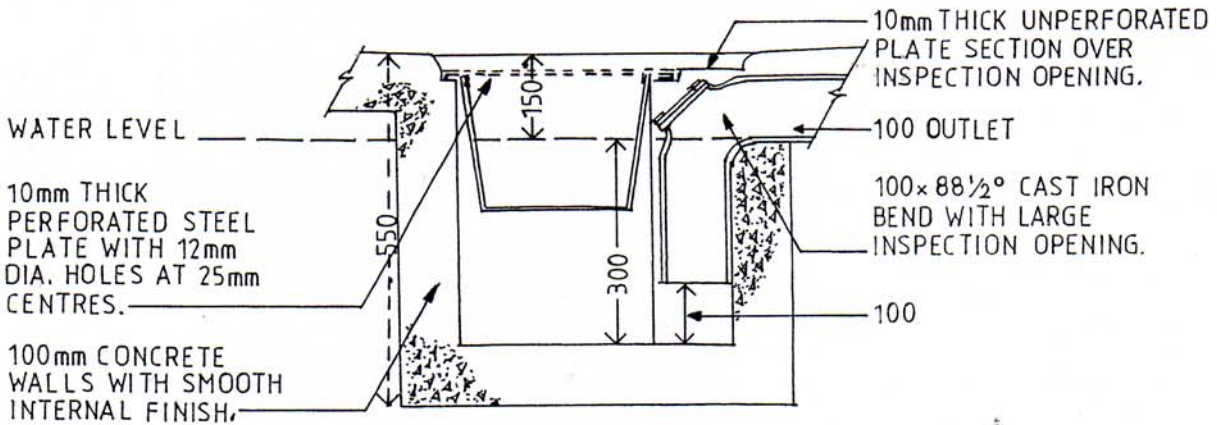

SECTION A-A

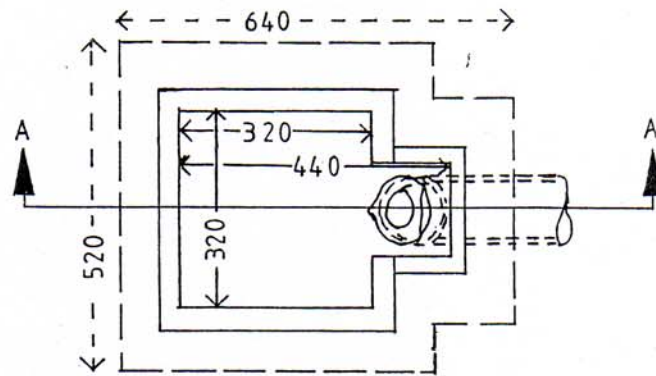

PIT PLAN (BUCKET & PLATE REMOVED)

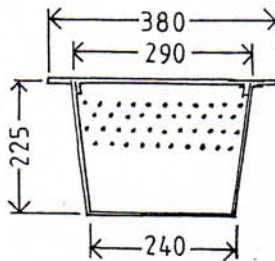

SECTION B-B

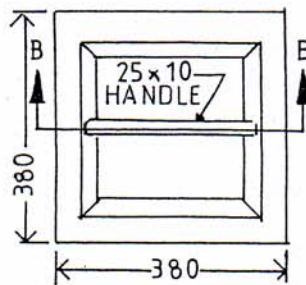

PLAN

BUCKET SPECIFICATION

BUCKET TO BE CONSTRUCTED OF 3mm THICK MILD STEEL PLATE WITH 4 ROWS OF 10mm DIA. HOLES AT 25mm CENTRES.

NOTE: SILT PIT TO BE INSTALLED AND CONNECTED IN ACCORDANCE WITH THE REQUIREMENTS OF THE LOCAL AUTHORITY.